

APPENDIX O

GRAY WATER RECYCLING SYSTEMS

(The provisions contained in this appendix are not mandatory unless specifically referenced in the adopting ordinance.)

Note: Section P2601.2 of the Florida Building Code, Residential requires all plumbing fixtures that receive water or waste to discharge to the sanitary drainage system of the structure. To allow for the use of a gray water recycling system, Section P2601.2 of the Florida Building Code, Residential should be revised to read as follows:

P2601.2 Connections. Plumbing fixtures, drains and appliances used to receive or discharge liquid wastes or sewage shall be directly connected to the sanitary drainage system of the building or premises, in accordance with the requirements of this code. This section shall not be construed to prevent indirect waste systems.

Exception: Bathtubs, showers, lavatories, clothes washers and laundry trays are not required to discharge to the sanitary drainage system where those fixtures discharge to an approved gray water recycling system. Any sewage that discharges from the building must be connected to a sanitary drainage system of the building or premises. The sanitary drainage system shall discharge either to public sewer or to an onsite sewage treatment and disposal system in accordance with the *State of Florida Standards for Onsite Sewage Treatment and Disposal Systems*, Chapter 64E-6, *Florida Administrative Code*.

SECTION AO101 GENERAL

AO101.1 Scope. The provisions of this appendix shall govern the materials, design, construction and installation of gray water systems for flushing of water closets and urinals [see Figures AO101.1(1)].

AO101.2 Definition. The following term shall have the meaning shown herein.

GRAY WATER. As defined by 381.0065(2)(b) and (d) *Florida Statutes*, “Graywater” means that part of domestic sewage that is not blackwater, including waste from the bath, lavatory, laundry and sink, except kitchen sink waste. “Blackwater” means that part of domestic sewage carried off by toilets, urinals and kitchen drains.

AO101.3 Permits. Permits shall be required in accordance with Section R105 of the *Florida Building Code, Residential*.

AO101.4 Installation. In addition to the provisions of Section AO101, systems for flushing of water closets and urinals shall comply with Section AO102. Except as provided for in Appendix O, all systems shall comply with the provisions of the *Florida Building Code, Residential*.

AO101.5 Materials. Above-ground drain, waste and vent piping for gray water systems shall conform to one of the standards listed in Table P3002.1(1) of the *Florida Building Code, Residential*. Gray water underground *building drainage* and

vent pipe shall conform to one of the standards listed in Table P3002.1(2) of the *Florida Building Code, Residential*.

AO101.6 Tests. Drain, waste and vent piping for gray water systems shall be tested in accordance with Section P2503 of the *Florida Building Code, Residential*.

AO101.7 Inspections. Gray water systems shall be inspected in accordance with Section P2503 of the *Florida Building Code, Residential*.

AO101.8 Potable water connections. Only connections in accordance with Section AO102.3 shall be made between a gray water recycling system and a potable water system.

AO101.9 Waste water connections. Gray water recycling systems shall receive the waste discharge only of bathtubs, showers, lavatories, clothes washers and laundry trays.

AO101.10 Filtration. Gray water entering the reservoir shall pass through an *approved* filter such as a media, sand or diatomaceous earth filter.

AO101.10.1 Required valve. A full-open valve shall be installed downstream of the last fixture connection to the gray water discharge pipe before entering the required filter.

AO101.11 Collection reservoir. Gray water shall be collected in an *approved* reservoir constructed of durable, nonabsorbent and corrosion-resistant materials. The reservoir shall be a closed and gas-tight vessel. Access openings shall be provided to allow inspection and cleaning of the reservoir interior.

AO101.12 Overflow. The collection reservoir shall be equipped with an overflow pipe of the same diameter as, or larger than, the influent pipe for the gray water. The overflow pipe shall be trapped and shall be indirectly connected to the sanitary drainage system.

AO101.13 Drain. A drain shall be located at the lowest point of the collection reservoir and shall be indirectly connected to the sanitary drainage system. The drain shall be the same diameter as the overflow pipe required in Section AO101.12.

AO101.14 Vent required. The reservoir shall be provided with a vent sized in accordance with Chapter 31 of the *Florida Building Code, Residential* and based on the diameter of the reservoir influent pipe.

**SECTION AO102
SYSTEMS FOR FLUSHING WATER
CLOSETS AND URINALS**

AO102.1 Collection reservoir. The holding capacity of the reservoir shall be a minimum of twice the volume of water required to meet the daily flushing requirements of the fixtures supplied with gray water, but not less than 50 gallons (189 L). The reservoir shall be sized to limit the retention time of gray water to a maximum of 72 hours.

AO102.2 Disinfection. Gray water shall be disinfected by an *approved* method that uses one or more disinfectants such as chlorine, iodine or ozone.

AO102.3 Makeup water. Potable water shall be supplied as a source of makeup water for the gray water system. The potable water supply shall be protected against backflow in accordance with Section P608. There shall be a full-open valve located on the makeup water supply line to the collection reservoir.

AO102.4 Coloring. The gray water shall be dyed blue or green with a food grade vegetable dye before such water is supplied to the fixtures.

AO102.5 Materials. Distribution piping shall conform to one of the standards listed in Table P2905.4.

AO102.6 Identification. Distribution piping and reservoirs shall be identified as containing nonpotable water. Piping identification shall be in accordance with Section 608.8 of the *Florida Building Code, Plumbing*.

**SECTION AO103
SUBSURFACE LANDSCAPE
IRRIGATION SYSTEMS
RESERVED**

⋮

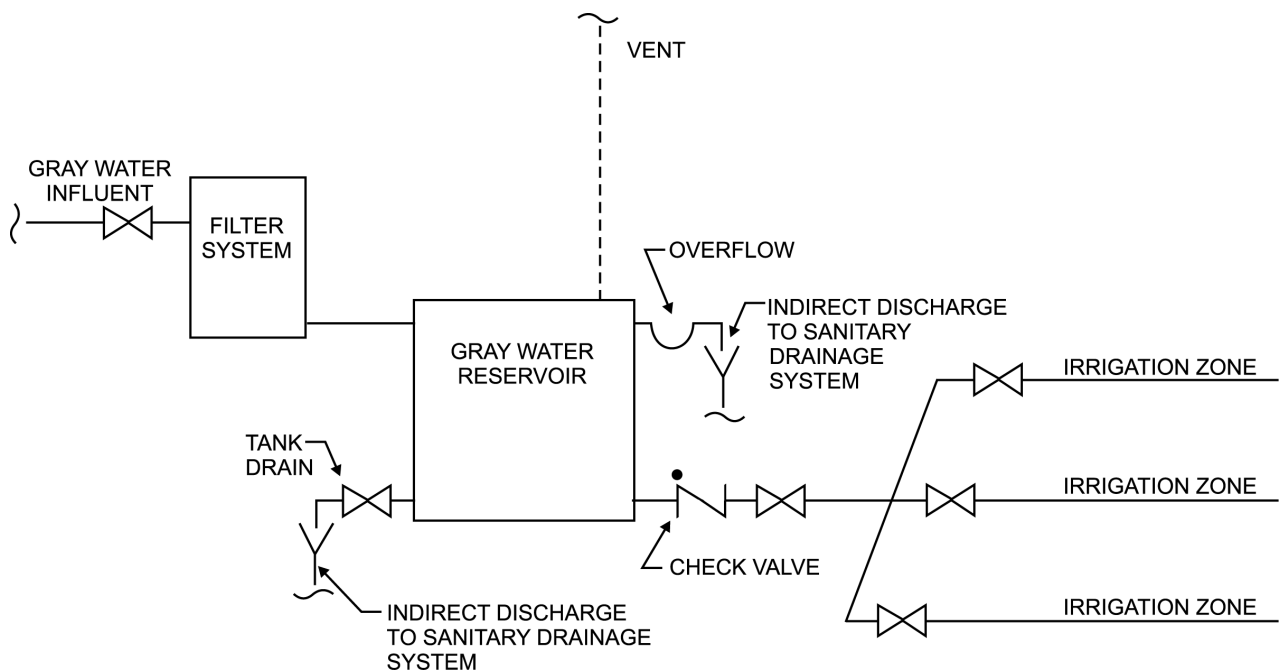

**FIGURE AO101.1(1)
GRAY WATER RECYCLING SYSTEM FOR SUBSURFACE LANDSCAPE IRRIGATION**